

Owner's Manual

Model: ATVBK-500 (5301231) (5-Nozzle Boom Assembly w/Connecting Fittings)

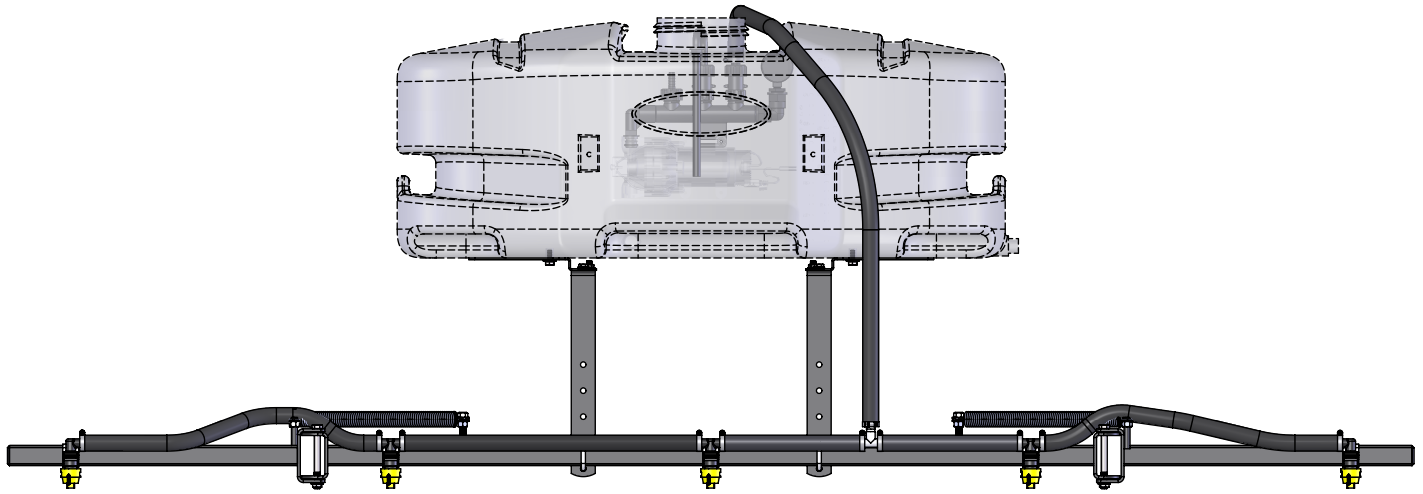

Technical Specifications

- 5-Nozzle Boom Assembly
- 100" Spray Coverage
- Corrosion-Resistant Nozzles

Assembly

Remove the parts to the boom assembly from the carton. Refer to the parts list and exploded view drawing to help identify all the components.

1. Attach the tank to the brackets loosely as shown in the exploded view.
2. Place the sprayer onto the carrier rack of the ATV. Use the u-bolts and hardware to secure the tank mount to the rack.
3. Connect the boom mounting brackets to the tank mounting brackets with hardware provided as shown. Note these brackets will be located about 16 1/4" apart on most ATV's. Now tighten all bolts and nuts.
4. Center the center section of the boom onto your boom mounts, and secure in place with the hardware provided. Be sure that the outer booms will fold 'backwards'. The boom should be about 17"-19" above the ground.
5. Attach the nozzle harness assembly to the boom, if not done so already. The end boom members should fold towards the rear of the sprayer.
6. Route your boom feeder hose around the unit, to the back end of the sprayer. Join the hose to the tee barb. Then clamp in place with a hose clamp.

CAUTION: Never use a metal object or other sharp item for cleaning a nozzle tip. It is better to use a nozzle brush (NOT wire brush) or compressed air for tip cleaning.



www.fimcoindustries.com

1000 FIMCO Lane, P.O. Box 1700, North Sioux City, SD 57049
Toll Free Phone: 800-831-0027 : Toll Free Fax: 800-494-0440

Form No. 730 [5004566 (02/12)] Printed in the U.S.A.

BEFORE RETURNING THIS PRODUCT
FOR ANY REASON, PLEASE CALL

1-800-831-0027

IF YOU SHOULD HAVE A QUESTION OR
EXPERIENCE A PROBLEM WITH YOUR
FIMCO INDUSTRIES PRODUCT:

1-800-831-0027

BEFORE YOU CALL, PLEASE HAVE THE
FOLLOWING INFORMATION AVAILABLE:
SALES RECEIPT & MODEL NUMBER. IN MOST
CASES, A FIMCO INDUSTRIES EMPLOYEE CAN
RESOLVE THE PROBLEM OVER THE PHONE.

General Information

Thank you for purchasing this product. The purpose of this manual is to assist you in operating and maintaining your boom kit. Please read it carefully, as it furnishes information which will help you achieve years of trouble-free operation.

Warranty/Parts/Service

For home usage, products are warranted for one year from date of purchase against manufacturer or workmanship defects.

Commercial users have a 90 day warranty.

Your authorized dealer is the best source of replacement parts and service. To obtain prompt, efficient service, always remember to give the following information...

- Correct Part Description and/or part number.
- Model number/Serial number of your sprayer.

Part descriptions and part numbers can be obtained from the illustrated parts list section(s) of this manual.

Whenever you need parts or repair service, contact your distributor/dealer first. For warranty work, always take your original sales slip, or other evidence of purchase date, to your distributor/dealer.

Testing the Sprayer

NOTE:

It is **VERY** important for you to test your sprayer with plain water before actual spraying is attempted. This will enable you to check the sprayer for leaks, without the possibility of losing any expensive chemicals.

Add water to the tank & drive to the starting place for spraying. When you are ready to spray, turn the boom valve to the "on" position. This will start solution spraying from the tips of the boom. The pressure will decrease slightly when the boom is spraying. Adjust the pressure by turning the "ON/OFF" valve lever on the bypass line valve.

Read the operating instructions and Initially begin spraying by closing the 'bypass' valve (this is the center ON/OFF valve located at the center port of your manifold assembly) and opening the boom line valve (this is the 'other' valve on the manifold). This will enable the air in the line to be eliminated (purged) through all the tips, while building pressure. When everything tests all right (no leaks, & good pressure), add the desired chemicals to the mixture and water combination and start your spraying operation. Adjust the pressure and spray as you did in the testing procedure.

Conditions of weather and terrain must be considered when setting the sprayer. Do not spray on windy days. Protective clothing must be worn in some cases.

Be sure to read the chemical label(s) correctly!

After Spraying

After use, fill the sprayer tank part way with water. Start the sprayer, and allow the clear water to be pumped through the plumbing system and out through the spray nozzles. Refill the tank about half full with plain water and use FIMCO Tank Neutralizer and Cleaner, and repeat cleaning instructions above. Flush the entire sprayer with the neutralizing/cleaning agent, then flush out one more time with plain water. Follow the chemical manufacturer's disposal instructions of all wash or rinsing water. For the boom, (if applicable) remove the tips and screens from the nozzle assemblies. Wash these items out thoroughly. Blow the orifice clean and dry. If the orifice remains clogged, clean it with a fine bristle (NOT WIRE) brush, or with a toothpick. Do not damage the orifice. Water rinse and dry the tips before storing.

WARNING: Some chemicals will damage the pump valves if allowed to soak untreated for a length of time! ALWAYS flush the pump as instructed after each use.

Rate Chart for (No. 2) Spray Tip (80°)											
Tip No.	Spray Height	Pressure (psi)	Capacity (GPM)	Gallons Per Acre - Based on Water							
				1 MPH	2 MPH	3 MPH	4 MPH	5 MPH	7.5 MPH	10 MPH	
2	18"	20	.14	41.8	20.9	14.0	10.5	8.4	5.6	4.2	
		30	.17	51.2	25.6	17.2	12.9	10.3	6.9	5.1	
		40	.20	59.2	29.6	19.8	14.9	11.9	7.9	5.9	
		50	.23	66.4	33.2	22.2	16.6	13.3	8.8	6.6	
Gallons Per 1000 Sq. Ft. - Based on Water											
Tip No.	Spray Height	Pressure (psi)	Capacity (GPM)	Gallons Per 1000 Sq. Ft. - Based on Water							
				1 MPH	2 MPH	3 MPH	4 MPH	5 MPH	7.5 MPH	10 MPH	
2	18"	20	.14	.96	.48	.32	.24	.19	.13	.10	
		30	.17	1.18	.59	.39	.30	.24	.16	.12	
		40	.20	1.36	.68	.45	.34	.27	.18	.14	
		50	.23	1.52	.76	.51	.38	.31	.20	.15	
Gallons Per 100 Sq. Ft. - Based on Water											
Tip No.	Spray Height	Pressure (psi)	Capacity (GPM)	Gallons Per 100 Sq. Ft. - Based on Water							
				1 MPH	2 MPH	3 MPH	4 MPH	5 MPH	7.5 MPH	10 MPH	
2	18"	20	.14	.096	.048	.032	.024	.019	.013	.010	
		30	.17	.118	.059	.039	.030	.024	.016	.012	
		40	.20	.136	.068	.045	.034	.027	.018	.014	
		50	.23	.152	.076	.051	.038	.031	.020	.015	

Calibration

Chemical labels may show application rates in gallons per acre, gallons per 1000 square feet, or gallons per 100 square feet. You will note that the tip chart shows all 3 of these rating systems.

Once you know how much you are going to spray, then determine (from the tip chart) the spraying pressure (PSI), and the spraying speed (MPH).

Determining the proper speed of the pulling vehicle can be done by marking off 100, 200, & 300 feet. The speed chart indicates the number of seconds it takes to travel the distances. Set the throttle and with a running start, travel the distances. Adjust the throttle until you travel the distances in the number of seconds indicated by the speed chart. Once you have reached the throttle setting needed, mark the throttle location so you can stop and go again, returning to the same speed.

Add water and proper amount of chemical to the tank and drive to the starting place for spraying.

Operation

Your sprayer is equipped with (2) ON/OFF switches. One is on the wire assembly that you hook up to your battery, the other is on the pump itself, on the opposite end of the pressure switch. The "-" is the "ON" position and the "o" is the "OFF" position for the switches. Make sure both switches are depressed in the "-" position for operation.

In addition to the ON/OFF switch, the pump is equipped with an electronic pressure switch that is factory pre-set for it to shut off at 35 p.s.i.. This switch assembly is the 'square box' on the head portion of the pump.

Always fill the tank with a desired amount of water first, and then add the chemical slowly, mixing as you pour the chemical into the tank. You may use the handgun to spray into the solution in order to mix the chemical and water.

Initially begin spraying by opening the handgun. This will enable the air in the line to be purged through the handgun tip, while building pressure.

The pumping system draws solution from the tank, through the strainer/filter, and to the pump. The pump forces the solution under pressure to the handgun and/or boom nozzles.

- Open the handgun by squeezing the handle lever.
- Rotating the adjustable nozzle tip on the handgun will change the tip pattern from a straight stream to a cone pattern (finer mist).

Winter Storage

Drain all water out of your sprayer, paying special attention to the pump, handgun, and valve(s). These items are especially prone to damage from chemicals and freezing weather.

The sprayer should be winterized before storage by pumping a solution of RV antifreeze through the entire plumbing system. This antifreeze solution should remain in the plumbing system during the winter months. When spring time comes and you are preparing your sprayer for the spray season, rinse the entire plumbing system out, clearing the lines of the antifreeze solution. Proper care and maintenance will prolong the life of your sprayer.

Speed Chart			
	Time Required in seconds to travel a distance of:		
Speed in M.P.H. (Miles per Hour)	100 Ft.	200 Ft.	300 Ft.
1.0	68 sec.	136 sec.	205 sec.
2.0	34	68	102
3.0	23	45	68
4.0	17	34	51
5.0	14	27	41
6.0	11	23	34
7.0	9.7	19	29
8.0	8.5	17	26
9.0	7.6	15	23
10.0	6.8	14	20

Exploded View/Parts List:
ATVBK-500 (5301231)

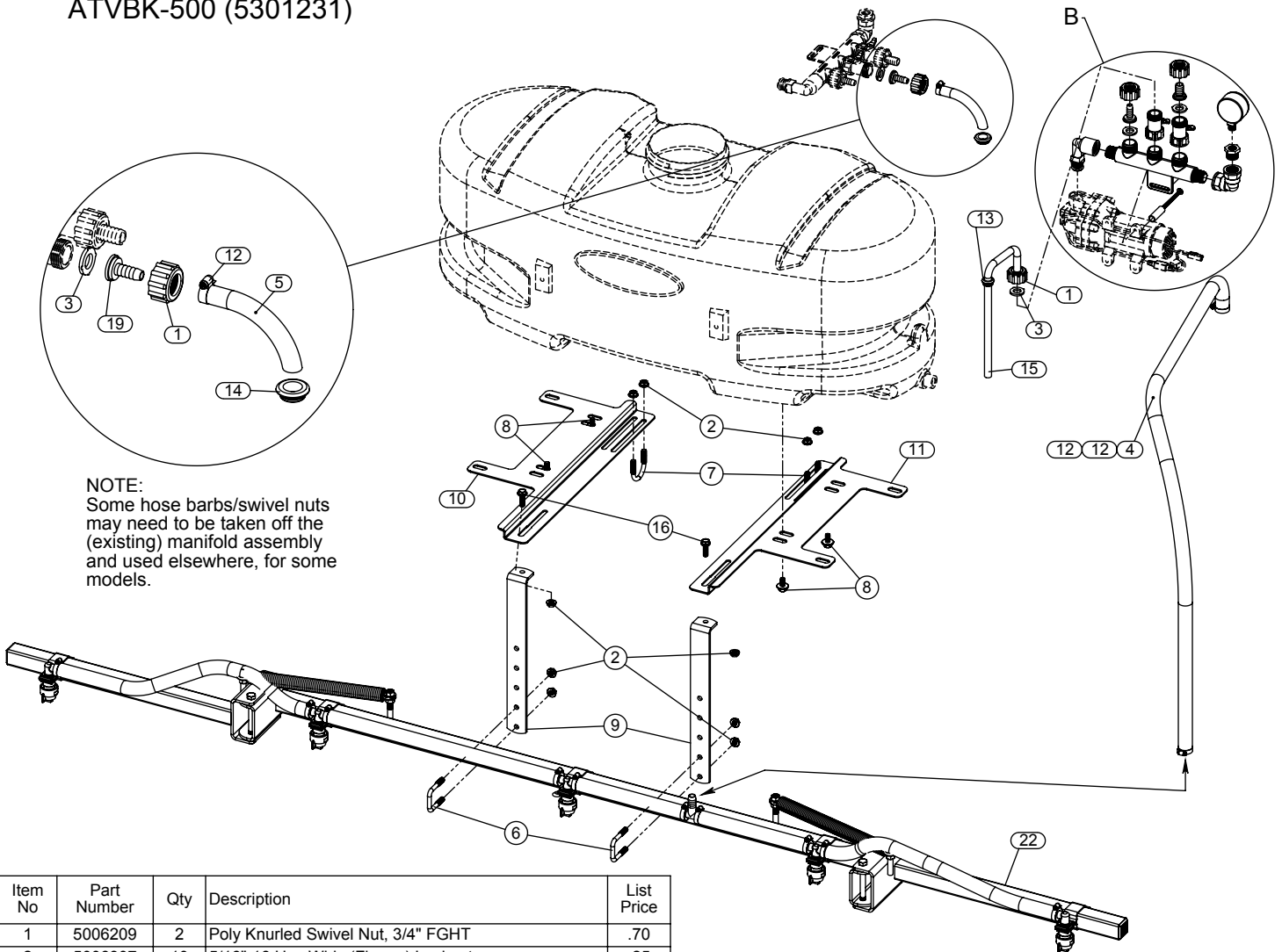

NOTE:
Some hose barbs/swivel nuts
may need to be taken off the
(existing) manifold assembly
and used elsewhere, for some
models.

Item No	Part Number	Qty	Description	List Price
1	5006209	2	Poly Knurled Swivel Nut, 3/4" FGHT	.70
2	5006307	10	5/16"-18 Hex Whiz (Flange) Locknut	.25
3	5016066	2	Garden Hose Washer	.20
4	5020122	1	Hose, 1/2"-1 Brd. x 48"	5.88
5	5020490	1	Hose, 3/8"-1 Brd. x 7 1/4"	1.25
6	5034159	2	Square U-Bolt, 5/16" x 1 5/16" x 1 7/8"	.99
7	5034220	2	Round U-Bolt, 5/16"-18 x 1 5/16" x 1 3/4"	.70
8	5034531	4	5/16"-18 x 5/8" Flange Lock Screw	.52
9	5038506	2	Boom Mounting Bracket	6.49
10	5038667	1	Tank Mounting Plate (L.H.) (ATV)	11.06
11	5038725	1	Tank Mounting Plate (R.H.) (ATV)	11.06
12	5051114	3	Hose Clamp (3/8"-1/2")	.63
13	5075018	1	Grommet	1.00
14	5075022	1	Grommet (5/8" I.D.)	1.00
15	5100359	1	Poly Bypass "J" Hose (3.8 Pumps & 2.1 [25] Gallon)	1.95
16	5117300	2	5/16"-18 x 1" Flange Whiz Lock Screw	.25
17	5117313	1	#10-24 x 2 1/2" Truss Head Machine Screw	.25
18	5127191	1	Manifold Spacer (2.1gpm)	.40
19	5149034	1	Poly Swivel, 3/8" Hose Barb	.65
20	5167007	1	Pressure Gauge, 0-100 p.s.i.	6.75
21	5275516	1	Manifold Assembly	19.50
21.1	5010430	1	Port Kit Elbow, 1/2" FNPT	2.79
21.2	5143405	1	Manifold w/Mounting Tab	6.99
21.3	5143188	2	Nylon Shut-Off Valve (3/4" GHT)	3.29
21.4	5016066	2	Garden Hose Washer	.20
21.5	5149034	1	Poly Swivel, 3/8" Hose Barb	.65
21.6	5149035	1	Poly Swivel, 1/2" Hose Barb	.65
21.7	5006209	2	Poly Knurled Swivel Nut, 3/4" FGHT	.70
21.8	5010236	1	Poly Elbow, 1/2" FNPT x 1/2" FNPT	2.50
21.9	5041073	1	Poly Reducing Bushing, 1/2" MNPT x 1/4" FNPT	1.41
22	5301966	1	Generic 5-Nozzle Boom Kit	179.50

Detail B

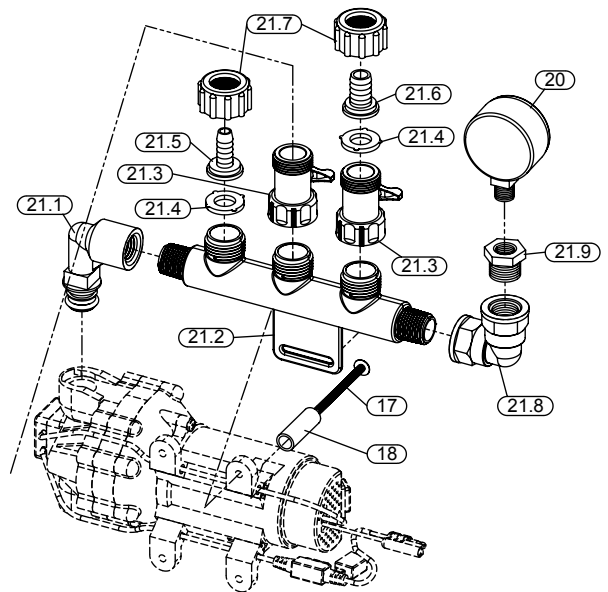

NOTE:
A pump is shown in this assembly, but
is NOT included with the boom kit.
Shown for connection purposes only.

(List Prices are Subject to Change)

5-Nozzle Boom Assembly #5301966

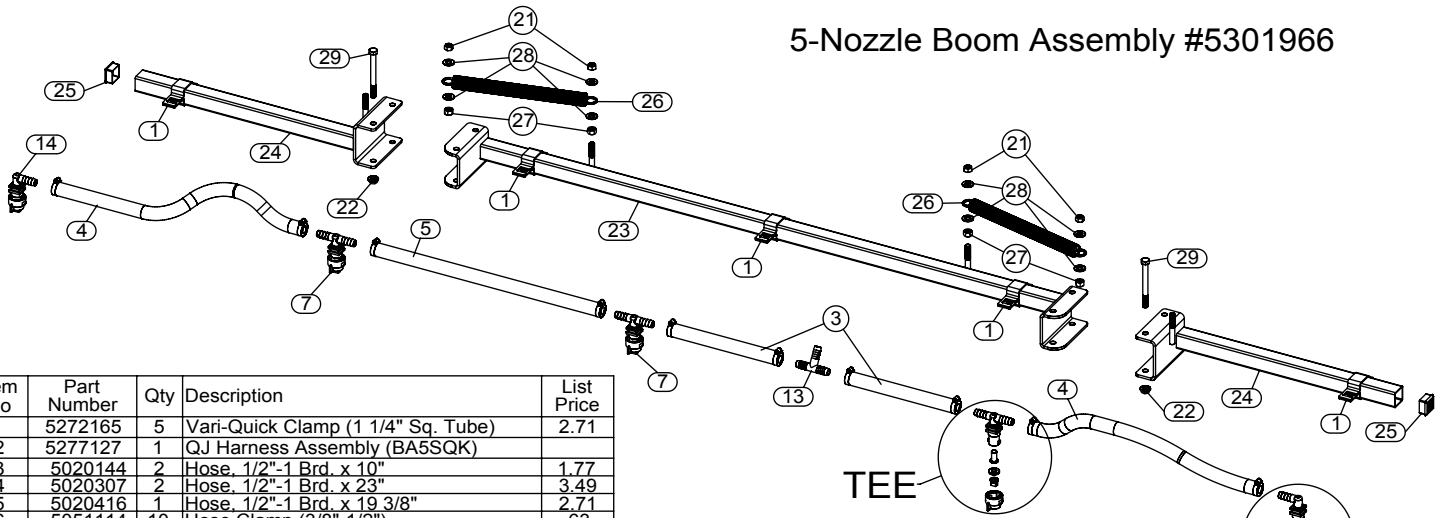

Item No	Part Number	Qty	Description	List Price
1	5272165	5	Vari-Quick Clamp (1 1/4" Sq. Tube)	2.71
2	5277127	1	QJ Harness Assembly (BA5SQK)	
3	5020144	2	Hose, 1/2"-1 Brd. x 10"	1.77
4	5020307	2	Hose, 1/2"-1 Brd. x 23"	3.49
5	5020416	1	Hose, 1/2"-1 Brd. x 19 3/8"	2.71
6	5051114	10	Hose Clamp (3/8"-1/2")	.63
7	5277028	3	QJ TEE Nozzle Assembly	
8	5056067	1	Double Hose Shank (1/2" Hose)	3.84
9	5116019	1	Nozzle Strainer, Red (50 Mesh)	1.21
10	5016157	1	Seat Washer (QJ Caps)	.47
11	5018265	1	80 Degree Flat Spray Tip, Yellow	.89
12	5046219	1	Quick TeeJet Cap ONLY (Yellow)	.77
13	5086003	1	Nylon Hose Tee, 1/2" HB	1.06
14	5277026	2	QJ ELL Nozzle Assembly	
15	5056065	1	Single Hose Shank (1/2" Hose)	3.84
16	5116019	1	Nozzle Strainer, Red (50 Mesh)	1.21
17	5016157	1	Seat Washer (QJ Caps)	.47
18	5018265	1	80 Degree Flat Spray Tip, Yellow	.89
19	5046219	1	Quick TeeJet Cap ONLY (Yellow)	.77
20	5277482	1	Boom Sub-Assembly (5-Nozzle)	
21	5006092	4	3/8"-16 Hex Locknut	.25
22	5006345	2	3/8"-16 Flange Locknut (Grade F)	.25
23	5274458	1	Center Boom Weldment (BK-70)	40.55
24	5277475	2	Outer Boom Weldment (5 Nozzle)	
25	5046344	2	Square Cap, Black (1 1/4" Square Tube)	.36
26	5019228	2	Extension Spring	5.50
27	5006054	4	3/8"-16 Hex Nut	.25
28	5016030	8	Flatwasher - 3/8"	.25
29	5034563	2	H.H.C.S. 3/8"-16nc x 3 3/4" long	.84

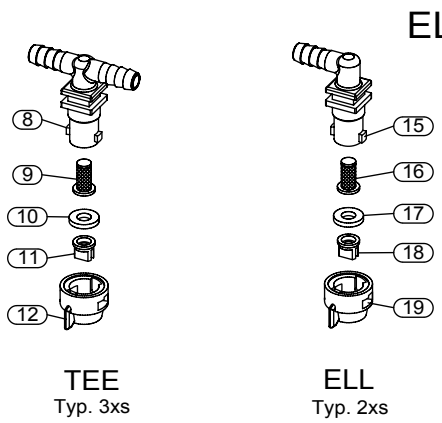

Typical Spray Pattern (5-Nozzle Boom)

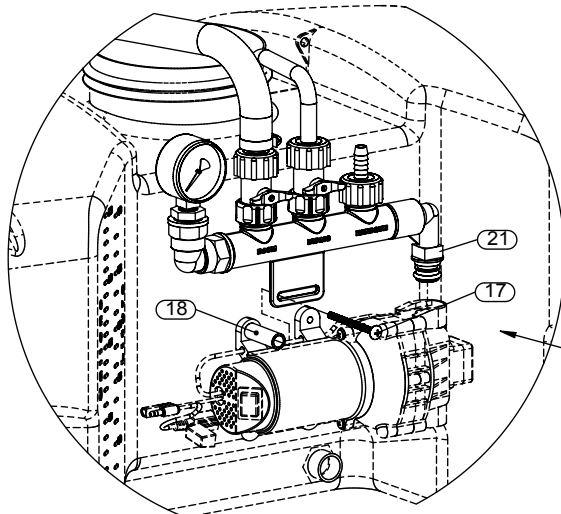
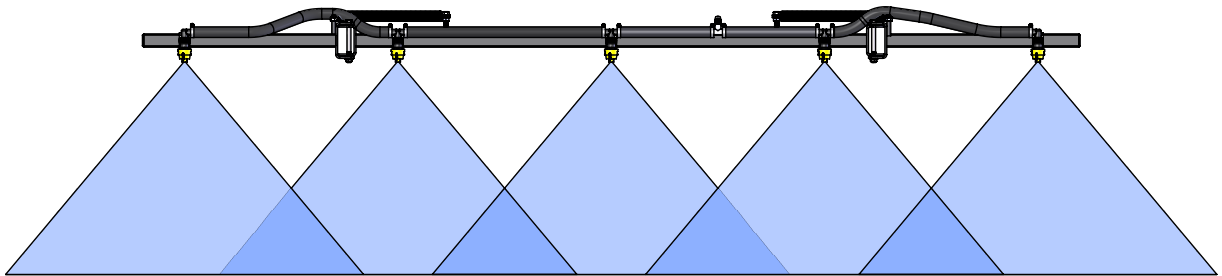

Manifold Spacer Attachment

NOTE:
To install the manifold spacer, remove one screw holding the pump to the tank (upper left location as you're looking at the pump) and place the spacer between the manifold and the pump's foot. Replace original screw with the 2-1/2" long machine screw, feeding it through the slot in the manifold and through the spacer, thus securing the manifold.