

OWNER'S MANUAL

Model: LG-25-PM
(5301146)

Model: LG-25-SM
(5301147)

(25 Gallon Lawn & Garden Spot Sprayers)

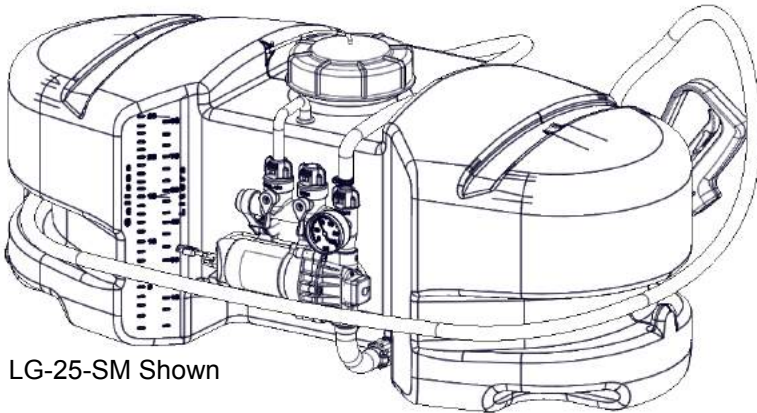

LG-25-SM Shown

**BEFORE RETURNING THIS PRODUCT
FOR ANY REASON, PLEASE CALL
1-800-831-0027**

**IF YOU SHOULD HAVE A QUESTION OR
EXPERIENCE A PROBLEM WITH YOUR
FIMCO INDUSTRIES PRODUCT:
1-800-831-0027**

**BEFORE YOU CALL, PLEASE HAVE THE
FOLLOWING INFORMATION AVAILABLE:
SALES RECEIPT & MODEL NUMBER. IN MOST
CASES, A FIMCO INDUSTRIES EMPLOYEE CAN
RESOLVE THE PROBLEM OVER THE PHONE.**

General Information

Thank you for purchasing this product. The purpose of this manual is to assist you in operating and maintaining your lawn & garden spot sprayer. Please read it carefully, as it furnishes information which will help you achieve years of trouble-free operation.

Warranty

Products are warranted for one year from date of purchase against manufacturer or workmanship defects for home owner usage and 90 days for commercial usage.

For technical assistance, visit our website @ www.fimcoindustries.com or call: **TOLL FREE @ 1-800-831-0027**

Our Technical Support Representatives will be happy to help you.

To obtain prompt, efficient service, always remember to give the following information...

- Correct Part Description and/or part number
- Model #/Serial # of your sprayer

Part descriptions and numbers can be obtained from the illustrated parts list section(s) of this manual.

Technical Specifications

- 25 Gal. Corrosion-Resistant Polyethylene Tank
- 12 Volt Diaphragm Pump, 2.1 g.p.m.—60 psi
- 15 Ft. Handgun Hose (3/8" I.D.)
- Pressure Gauge (Adjustable Pressure)

Assembly Instructions

Your sprayer has been mostly assembled at the factory. One requirement will be for you to hook up your battery leads to a fully charged 12 Volt battery. The red wire must be connected to the "hot" lead and the black wire should be connected to the ground.

Remove the handgun clips from the parts bag and place them onto the tank as shown.

Remove the Pressure Gauge from the parts bag and thread it into the manifold assembly. Use a good grade of thread sealant or plumber's tape to ensure no leaks.

CAUTION: Always check the vehicle load rating before using this sprayer. Do not exceed the recommended rating.

IMPORTANT REMINDER

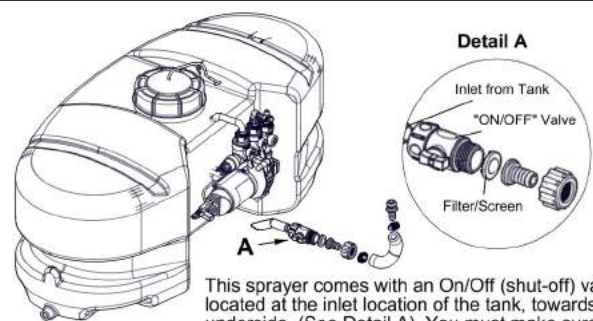

www.fimcoindustries.com

1000 FIMCO Lane, P.O. Box 1700, North Sioux City, SD 57049
Toll Free Phone: 800-831-0027 : Toll Free Fax: 800-494-0440

[5004805

(12/15)]

STOP WARNING STOP
DO NOT USE PUMP IN AN EXPLOSIVE ENVIRONMENT. DO NOT USE TO PUMP FLAMMABLE FLUIDS, GASOLINE, KEROSENE, FUEL, OIL, ETC.

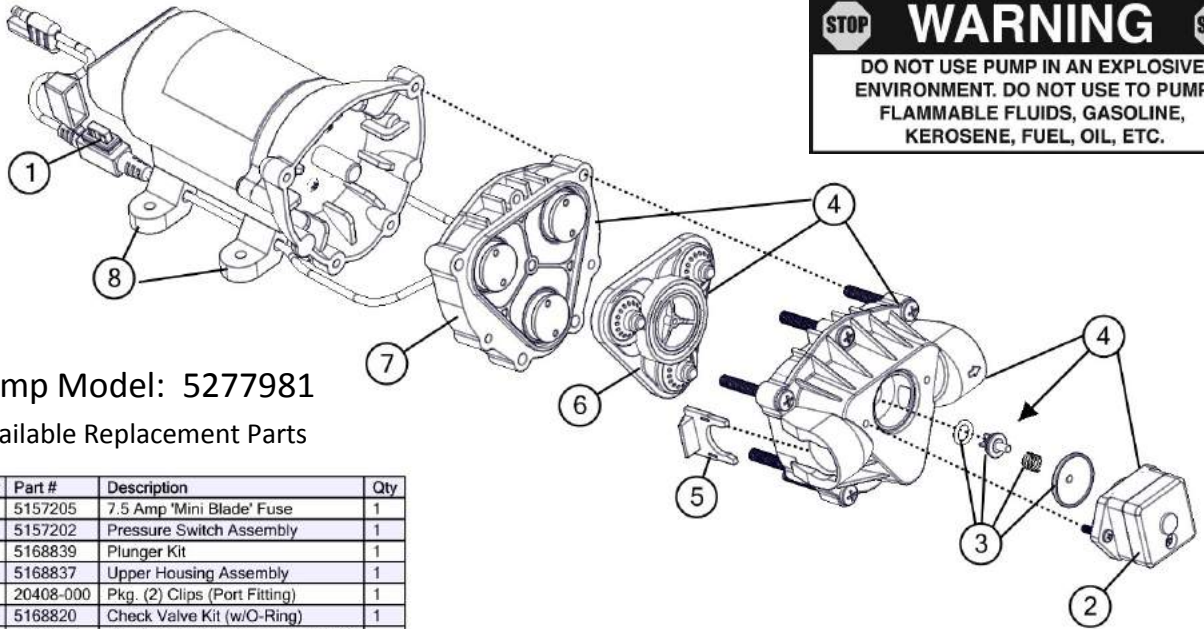

Pump Model: 5277981
Available Replacement Parts

Ref #	Part #	Description	Qty
1	5157205	7.5 Amp 'Mini Blade' Fuse	1
2	5157202	Pressure Switch Assembly	1
3	5168839	Plunger Kit	1
4	5168837	Upper Housing Assembly	1
5	20408-000	Pkg. (2) Clips (Port Fitting)	1
6	5168820	Check Valve Kit (w/O-Ring)	1
7	5168838	Diaphragm/Piston/Cam/Bearing Kit	1
8	5095202	Mounting Feet (Pkg of 4)	1

DO

- Clean and rinse your pump after each use with Fimco Tank Neutralizer
- Winterize your pump or sprayer by rinsing, draining and running RV Antifreeze through it before storing for the winter.
- Use clean water for your spray mixture
- Store inside a building when not in use.

DON'T

- Use to pump bleach.
- Use to pump petroleum products such as diesel fuel, gasoline or kerosene
- Leave your pump sit with spray mixture in it for extended periods
- Use dirty or unfiltered water for spraying

CAUTION
PRESSURE SWITCH OPERATION
 Pressure switch is pre-set at the factory. Improper adjustment of the pressure switch, may cause severe overload or premature failure. If the pump is subjected to rapid cycling during normal operation, or infrequent periods, damage may occur.

Troubleshooting the Pump:

Motor does not run:

- Check for loose wiring connection(s).
- Make sure the 'ON/OFF' switch in the lead wire assembly is in the 'ON' position. "I" is the 'ON' position and 'O' is the 'OFF' position.
- Check for defective pressure switch. Make sure you are connected to a good 12 volt power source. Make sure any on/off switches are in the 'on' position.
- Remove the cap to the pressure switch. Pull both red wires off of their terminals, and touch the two ends together. If your pump runs when you do this, your pressure switch will need to be replaced.
- Check the fuse.
- Check for low voltage at the power supply.

Pump does not prime:

- Check for air leaks in supply line.
- Check for debris in the check valve assembly.
- Check for defective check valve.
- Check for clogged strainer/filter.
- Check for cracks in the pump housing.
- Check for empty product supply.

Pulsating flow (surging):

- Check for defective pressure switch.
- Check for leaks in the discharge line.
- Check for restriction in the discharge line.
- Check for debris in nozzle orifice.
- Discharge hose may be too long.
- Check for clogged strainer.

Motor continues to run after discharge is shut off:

- Check for empty product supply.
- Check for open bypass valve. (if equipped)
- Check for low voltage.
- Check for leak in discharge line.
- Check for defective or dirty check valve.
- Check for defective pressure switch.

Pump Specifications	
Current:	4.5 Amps @ 30 PSI
Check Valve:	Viton
Wetted Parts Housing:	Polypropylene
Diaphragm:	Santoprene
Liquid Temperature:	130° F max.

GPM=Gallons Per Minute
 PSI=Pounds per Square Inch
 DC=Direct Current

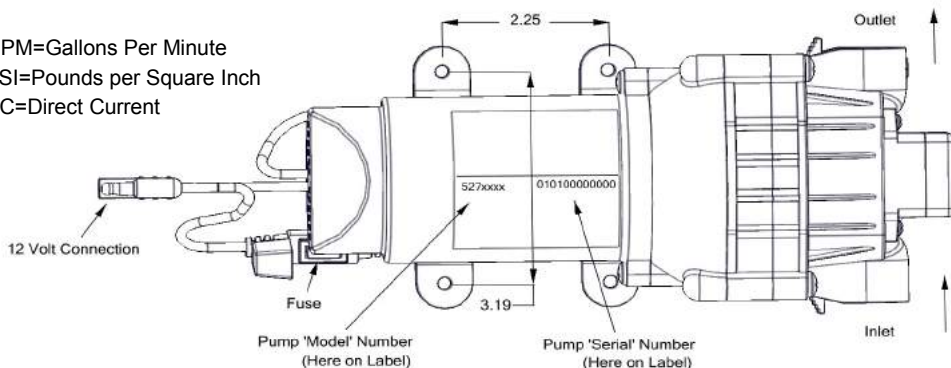

Testing the Sprayer

NOTE:

It is **VERY** important for you to test your sprayer with plain water before actual spraying is attempted. This will enable you to check the sprayer for leaks without the possibility of losing any expensive chemicals.

Conditions of weather and terrain must be considered when setting the sprayer. Do not spray on windy days. Protective clothing must be worn in some cases

Be sure to read the chemical label(s) before application!

Operation

Your sprayer is equipped with (1) ON/OFF switch in the wire assembly that you hook up to your battery. The "o" is the "ON" position and the "o" is the "OFF" position for the switch. Make sure the switch is depressed in the "-" position for operation.

The pump is equipped with a pressure switch that is factory pre-set for it to shut off at 60 p.s.i. This switch assembly is the 'square box' on the head portion of the pump.

Always fill the tank 1/2 full with water first and then add the chemical slowly, mixing as you pour the chemical into the tank and then fill the rest of the way. You may use the bypass in order to mix the chemical and water.

The pumping system draws solution from the tank, through the strainer/filter and to the pump. The pump forces the solution under pressure to the handgun.

- Activate the handgun by squeezing the handle lever
- Rotating the adjustable nozzle tip on the handgun will change the tip pattern from a straight stream to a cone pattern (fine mist)

After Spraying

After use, fill the sprayer tank part way with water. Start the sprayer and allow the clear water to be pumped through the plumbing system and out through the spray nozzle. Refill the tank about half full with plain water and use FIMCO Tank Neutralizer and Cleaner and repeat cleaning instructions above. Flush the entire sprayer with the neutralizing/cleaning agent, then flush out one more time with plain water. Follow the chemical manufacturer's disposal instructions of all wash or rinsing water.

WARNING: Some chemicals will damage the pump valves if allowed to soak untreated for a length of time! ALWAYS flush the pump as instructed after each use. DO NOT allow chemicals to sit in the pump for extended times of idleness. Follow the chemical manufacturer's instructions on disposal of all waste water from the sprayer.

Winter Storage

Drain all water out of your sprayer, paying special attention to the pump, handgun and valve(s). These items are especially prone to damage from chemicals and freezing weather. The sprayer should be winterized before storage by pumping a solution of RV antifreeze through the entire plumbing system. This antifreeze solution should remain in the plumbing system during the winter months. When spring time comes and you are preparing your sprayer for the spray season, rinse the entire plumbing system out, clearing the lines of the antifreeze solution. Proper care and maintenance will prolong the life of your sprayer.

Intake/Siphon Tube/Screen Detail of a Typical L&G/ATV Sprayer (not including the 'EC' Units)

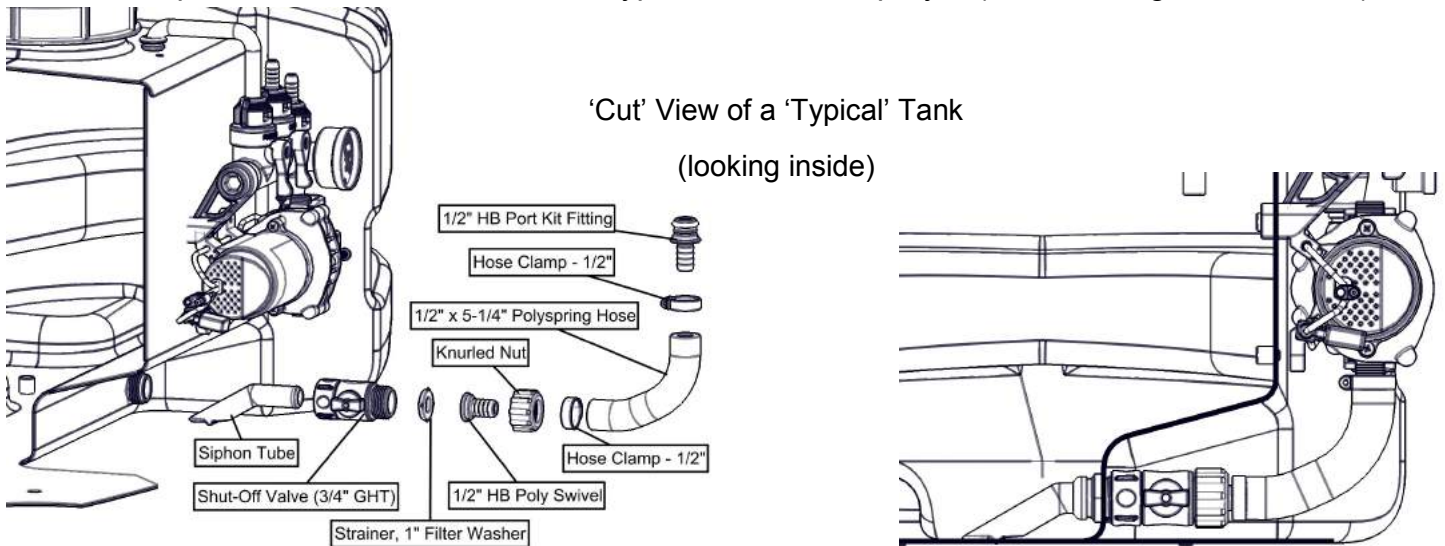

The suction line of your sprayer should contain a 'siphon tube' or intake tube which should be rotated so that it just touches the bottom of the tank surface. (see Detail Views). Reach in and rotate it, as needed, if not already in this position.

A nylon shut-off valve is threaded onto the pipe nipple at the intake location on the tank. It is at this location so you can shut off the flow of solution to access your system's screen for cleaning.

Checking/Cleaning the sprayer's filter/screen:

- ◆ Start your pump and before it shuts off, reach down and Shut the nylon valve to the 'Closed' position (lever is perpendicular to the flow of fluid), then shut off your pump.
- ◆ Unscrew the knurled nut from the shut-off valve, leaving the valve connected to the tank.
- ◆ Swing (swivel) the intake assembly towards you. Look in the nut you JUST unscrewed. There is a screen/washer there.
- ◆ Remove the screen and clean as necessary. Replace when done and reassemble the entire assembly.
- ◆ Make sure the valve is turned to the 'Open' position before restarting your pump.

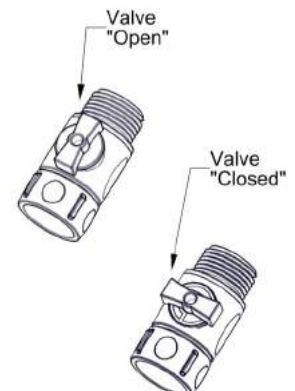

Exploded View/Parts List:

LG-25-PM (5301146)

LG-25-SM (5301147)

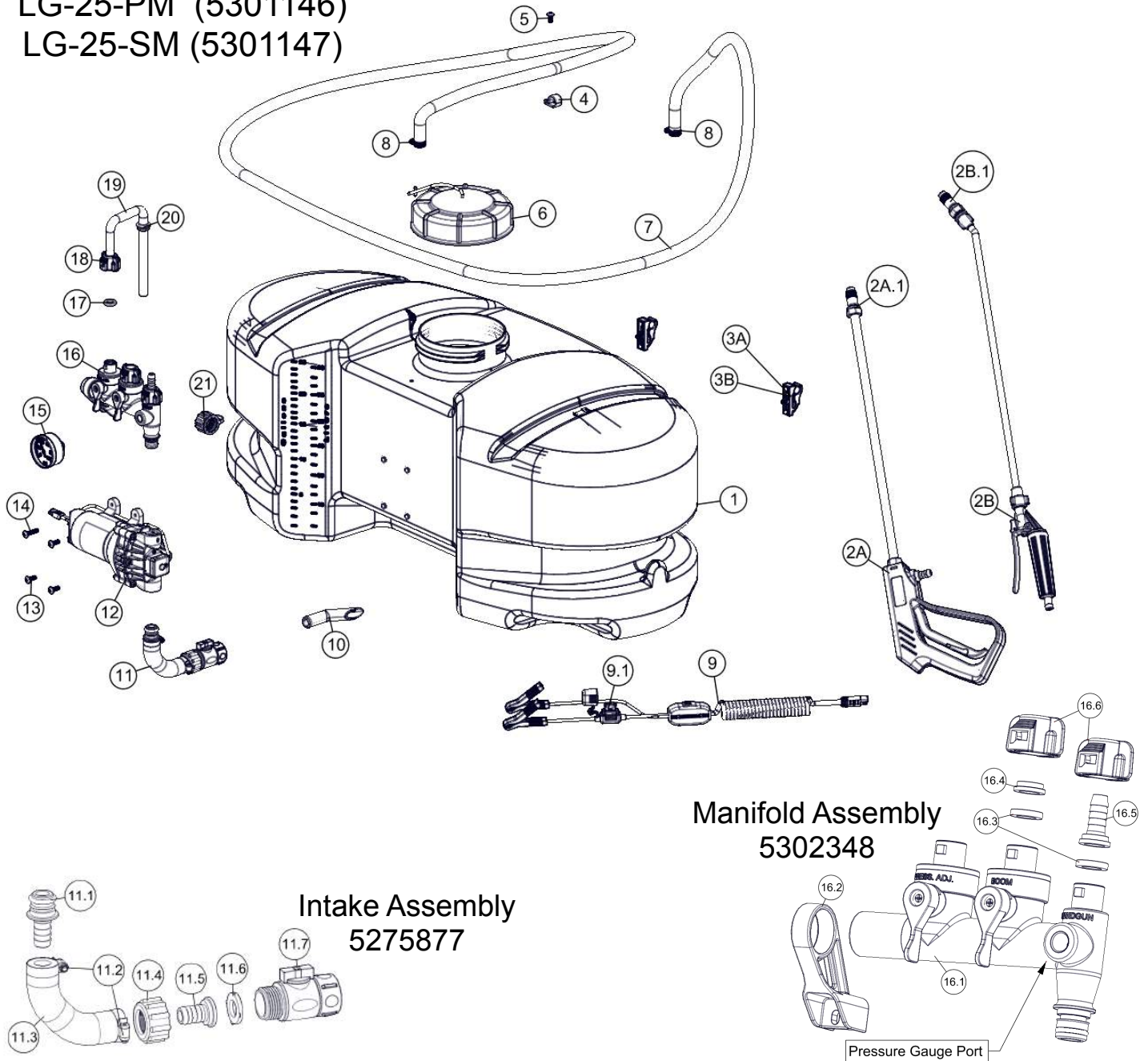

**Intake Assembly
5275877**

**Manifold Assembly
5302348**

Ref. #	Part #	Description	Qty
1	5169243	25 Gallon Tank (White)	1
2A	5273959	Deluxe Pistol-Grip Handgun w/X-26 Tip (LG-25-SM)	1
2A.1	5018331	Brass Handgun Tip (X-26) (LG-25-SM)	1
2B	5163100	Low-Flow Handgun w/X-26 Tip (LG-25-PM)	1
2B.1	5018330	Handgun Tip (X-26) (LG-25-PM)	1
3A	5278348	Deluxe Wand Clip & Screws (Pkg/2) (LG-25-SM)	1
3B	5274880	Wand Clip & Screws (Pkg/2) (LG-25-PM)	1
4	5051122	5/8" Black Nylon Loom Cable Clamp	1
5	5117234	#10-24 x 1/2" Phillips Truss Head Machine Screw	1
6	5058188	Tank Lid w/Lanyard	1
7	5020524	Hose, 3/8"-1 Brd. x 15 Ft.	1
8	5051144	Hose Clamp, 3/8"	2
9	5278114	Lead Wire Assembly w/15A Fuse & 30A Clips (96" Long)	1
9.1	5157238	15 Amp Regular Blade Fuse	1
10	5100452	Siphon Tube	1
11	5275877	Intake Sub-Assembly	1
11.1	5168833	Port Kit Fitting, 1/2" Hose Barb	1
11.2	5051114	Hose Clamp, 1/2"	2
11.3	5020557	1/2" Polyspring Hose x 5 1/4"	1
11.4	5006209	Poly Knurled Swivel Nut, 3/4" FGHT	1

Ref. #	Part #	Description	Qty
11.5	5149035	Poly Swivel, 1/2" Hose Barb	1
11.6	5116242	Strainer, 1" Filter Washer	1
11.7	5143419	Swivel Shut-Off	1
12	5277981	High Flo Gold Series 2.1 GPM Pump	1
13	5117167	#10-24 x 5/8" Phillips Truss Head Machine Screw	3
14	5117168	#10-24 x 1" Phillips Truss Head Machine Screw	1
15	5167097	2" Dry 100# Back Mount Gauge	1
16	5302348	Quick Connect Manifold Assembly	1
16.1	5302347	Quick Connect Manifold	1
16.2	5143422	QC Manifold - Support Bracket	1
16.3	5143430	Flat Washer - Hose Barb Seal	2
16.4	5143435	QC Manifold - Quarter Turn Cap Plug	1
16.5	5143431	QC Manifold - 3/8" Hose Barb - Straight	1
16.6	5143429	QC Manifold - QC Quarter Turn Cap	2
17	5143430	Flat Washer - Hose Barb Seal	1
18	5143429	QC Manifold - QC Quarter Turn Cap	1
19	5100803	Rigid By-Pass Tube Assembly	1
20	5075018	Grommet, 1/2" I.D.	1
21	5274373	Drain Plug Cap, Tether, and Washer Assembly	1